

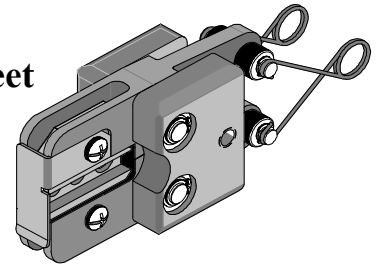

Air Powered Crimp Tool Head
Operating Instruction and Specifications Sheet
Order No. 64007-0100
Eng. No. AT 1992
(Replaces 19282-0015)



FEATURES

- Quick-change tool head for the 19279-0001 (AT-200)
- Tooling kit is interchangeable with other kits in the 64001 and 64003 Series
- A precision user-friendly terminal locator wire stop holds terminals in the proper crimping position for each of the three nests
- 3-nested tool eliminates the need for additional tools
- Pneumatic powered crimp tools help reduce fatigue and discomfort from repetitive manual crimping

SCOPE

Products: Krimptite™ / VersaKrimp™ Terminals and Splices 10–22 AWG. This tool head is intended for use in the 19279-0001 (AT-200) either hand held or with optional bench adapter 19078-0307 (ATBA) and foot switch.

Testing

Mechanical

The tensile test, or pull test, is a means of evaluating the mechanical properties of the crimped connections. The following charts show the UL and Government specifications (MIL-T-7928) for various wire sizes. The tensile strength is shown in pounds and indicates the minimum acceptable force to break or separate the terminal from the conductor.

Wire Size (AWG)	*UL - 486 A	*UL - 486 C	**Military
22	8	8	15
20	13	10	19
18	20	10	38
16	30	15	50
14	50	25	70
12	70	35	110
10	80	40	150

*UL - 486 A - Terminals (Copper conductors only)

*UL - 486 C - Butt Splices, Parallel Splices

**Military – Military Approved Terminals only as listed

The following is a partial list of the product part numbers and their specifications that this tool is designed to run. We will be adding to this list and an up to date copy is available on www.molex.com

Wire Size: 18 – 22 AWG 0.80 – 0.35 mm ²			
Terminal No.	Terminal Eng No. (REF)	Wire Strip Length	
		In	mm
19022-0004	AMCT-1	0.281	7.137
19033-0001	A-159	0.281	7.137

Wire Size: 18 – 22 AWG 0.80 – 0.35 mm ²			
Terminal No.	Terminal Eng No. (REF)	Wire Strip Length	
		In	mm
19033-0003	A-169	0.281	7.137
19041-0005	A-142-10	0.281	7.137

Wire Size: 18 – 22 AWG 0.80 – 0.35 mm ²				Wire Size: 18 – 22 AWG 0.80 – 0.35 mm ²			
Terminal No.	Terminal Eng No. (REF)	Wire Strip Length		Terminal No.	Terminal Eng No. (REF)	Wire Strip Length	
		In	mm			In	mm
19044-0034	A-120-04	0.281	7.137	19069-0051	AA-126-56	0.188	4.763
19044-0063	A-120-02	0.281	7.137	19069-0052	AA-132-04	0.188	4.763
19044-0066	A-120-06	0.281	7.137	19069-0054	AA-132-06	0.188	4.763
19044-0068	A-121-06	0.281	7.137	19069-0056	AA-132-08	0.188	4.763
19044-0069	A-121-08	0.281	7.137	19069-0061	AA-133-10	0.188	4.763
19044-0070	A-121-08R90	0.281	7.137	19079-0004	A-1006-MS	0.281	7.137
19044-0072	A-121-10	0.281	7.137	19086-0020	A-105-04	0.281	7.137
19044-0074	A-122-10	0.281	7.137	19086-0021	A-105-06	0.281	7.137
19044-0075	A-122-14	0.281	7.137	19086-0023	A-106-06	0.281	7.137
19044-0078	A-126-10	0.281	7.137	19086-0024	A-106-08	0.281	7.137
19044-0079	A-126-14	0.281	7.137	19086-0025	A-106-10	0.281	7.137
19044-0081	A-126-38	0.281	7.137	19086-0026	A-114-04	0.281	7.137
19044-0082	A-126-56	0.281	7.137	19086-0027	A-114-06	0.281	7.137
19044-0083	A-132-04	0.281	7.137	19086-0028	A-114-08	0.281	7.137
19044-0084	A-132-06	0.281	7.137	19086-0029	A-192-06	0.281	7.137
19044-0086	A-132-08	0.281	7.137	19086-0030	A-192-08	0.281	7.137
19044-0090	A-133-08	0.281	7.137	19086-0031	A-192-10	0.281	7.137
19044-0091	A-133-10	0.281	7.137	19086-0032	A-195-06	0.281	7.137
19044-0213	A-121-04	0.281	7.137	19086-0033	A-195-08	0.281	7.137
19056-0006	A-320-02	0.281	7.137	19086-0034	A-195-10	0.281	7.137
19056-0008	A-320-04	0.281	7.137	19086-0035	A-198-04	0.281	7.137
19056-0010	A-320-06	0.281	7.137	19086-0036	A-198-06	0.281	7.137
19056-0013	A-321-06	0.281	7.137	19086-0037	A-198-08	0.281	7.137
19056-0015	A-321-08	0.281	7.137	19086-0038	A-198-10	0.281	7.137
19056-0018	A-321-10	0.281	7.137	19086-0110	A-L80-08	0.296	7.518
19056-0021	A-322-10	0.281	7.137	19086-0112	A-L81-06	0.296	7.518
19056-0023	A-322-14	0.281	7.137	19086-0114	A-L83-05	0.296	7.518
19056-0025	A-322-56	0.281	7.137	19086-0116	A-L84-06	0.296	7.518
19056-0027	A-326-10	0.281	7.137	19086-0117	A-L85-04	0.296	7.518
19056-0029	A-326-14	0.281	7.137	19086-0118	A-L86-04	0.296	7.518
19056-0031	A-326-38	0.281	7.137	19086-0151	A-L82-08	0.296	7.518
19056-0033	A-326-56	0.281	7.137	19087-0029	AA-105-04	0.188	4.763
19056-0035	A-332-04	0.281	7.137	19087-0037	AA-1110-02	0.188	4.763
19056-0037	A-332-06	0.281	7.137	19087-0039	AA-1110-04	0.188	4.763
19056-0039	A-332-08	0.281	7.137	19087-0041	AA-114-04	0.188	4.763
19056-0044	A-333-10	0.281	7.137	19087-0043	AA-114-06	0.188	4.763
19069-0024	AA-1111-02	0.188	4.763	19087-0045	AA-114-08	0.188	4.763
19069-0025	AA-1111-04	0.188	4.763	19087-0054	AA-192-06	0.188	4.763
19069-0027	AA-120-02	0.188	4.763	19087-0056	AA-192-08	0.188	4.763
19069-0029	AA-120-04	0.188	4.763	19087-0058	AA-192-10	0.188	4.763
19069-0031	AA-120-06	0.188	4.763	19087-0060	AA-195-06	0.188	4.763
19069-0033	AA-121-06	0.188	4.763	19087-0062	AA-195-08	0.188	4.763
19069-0035	AA-121-08	0.188	4.763	19087-0064	AA-195-10	0.188	4.763
19069-0037	AA-121-10	0.188	4.763	19087-0066	AA-198-04	0.188	4.763
19069-0040	AA-122-10	0.188	4.763	19087-0068	AA-198-06	0.188	4.763
19069-0042	AA-122-14	0.188	4.763	19087-0070	AA-198-08	0.188	4.763
19069-0043	AA-122-14R90	0.188	4.763	19087-0072	AA-198-10	0.188	4.763
19069-0045	AA-122-56	0.188	4.763	19088-0001	A-305-04	0.281	7.137
19069-0047	AA-126-10	0.188	4.763	19088-0002	A-305-06	0.281	7.137
19069-0048	AA-126-14	0.188	4.763	19088-0004	A-306-06	0.281	7.137
19069-0049	AA-126-38	0.188	4.763	19088-0005	A-306-08	0.281	7.137

Wire Size: 18 – 22 AWG 0.80 – 0.35 mm ²				Wire Size: 18 – 22 AWG 0.80 – 0.35 mm ²			
Terminal No.	Terminal Eng No. (REF)	Wire Strip Length		Terminal No.	Terminal Eng No. (REF)	Wire Strip Length	
		In	mm			In	mm
19088-0006	A-306-10	0.281	7.137	19117-0028	A-193-10	0.281	7.137
19088-0007	A-314-04	0.281	7.137	19117-0029	A-196-04	0.281	7.137
19088-0008	A-314-06	0.281	7.137	19117-0030	A-196-06	0.281	7.137
19088-0009	A-314-08	0.281	7.137	19117-0031	A-196-08	0.281	7.137
19088-0010	A-392-06	0.281	7.137	19118-0018	AA-1108-02	0.188	4.763
19088-0011	A-392-08	0.281	7.137	19118-0019	AA-1108-04	0.188	4.763
19088-0012	A-392-10	0.281	7.137	19118-0020	AA-115-04	0.188	4.763
19088-0013	A-395-06	0.281	7.137	19118-0021	AA-115-06	0.188	4.763
19088-0014	A-395-08	0.281	7.137	19118-0023	AA-115-08	0.188	4.763
19088-0015	A-395-10	0.281	7.137	19118-0025	AA-115-10	0.188	4.763
19088-0016	A-398-04	0.281	7.137	19118-0026	AA-1461-04	0.188	4.763
19088-0017	A-398-06	0.281	7.137	19118-0027	AA-1461-06	0.188	4.763
19088-0018	A-398-08	0.281	7.137	19118-0028	AA-1461-08	0.188	4.763
19088-0019	A-398-10	0.281	7.137	19118-0029	AA-1461-10	0.188	4.763
19089-0031	AA-105-06	0.188	4.763	19118-0030	AA-190-06	0.188	4.763
19093-0001	AA-305-04	0.188	4.763	19118-0031	AA-190-08	0.188	4.763
19093-0003	AA-305-06	0.188	4.763	19118-0032	AA-190-10	0.188	4.763
19093-0009	AA-3110-02	0.188	4.763	19118-0033	AA-193-06	0.188	4.763
19093-0011	AA-3110-04	0.188	4.763	19118-0034	AA-193-08	0.188	4.763
19093-0013	AA-314-04	0.188	4.763	19118-0035	AA-193-10	0.188	4.763
19093-0015	AA-314-06	0.188	4.763	19118-0037	AA-196-04	0.188	4.763
19093-0017	AA-314-08	0.188	4.763	19118-0038	AA-196-06	0.188	4.763
19093-0019	AA-392-06	0.188	4.763	19118-0039	AA-196-08	0.188	4.763
19093-0021	AA-392-08	0.188	4.763	19123-0003	A-315-04	0.281	7.137
19093-0023	AA-392-10	0.188	4.763	19123-0004	A-315-06	0.281	7.137
19093-0025	AA-395-06	0.188	4.763	19123-0005	A-315-08	0.281	7.137
19093-0027	AA-395-08	0.188	4.763	19123-0006	A-3461-04	0.281	7.137
19093-0029	AA-395-10	0.188	4.763	19123-0007	A-3461-06	0.281	7.137
19093-0031	AA-398-04	0.188	4.763	19123-0008	A-3461-08	0.281	7.137
19093-0033	AA-398-06	0.188	4.763	19123-0009	A-3461-10	0.281	7.137
19093-0035	AA-398-08	0.188	4.763	19123-0010	A-390-06	0.281	7.137
19093-0037	AA-398-10	0.188	4.763	19123-0011	A-390-08	0.281	7.137
19098-0011	AA-1190-06	0.188	4.763	19123-0012	A-390-10	0.281	7.137
19098-0013	AA-1191-08	0.188	4.763	19123-0013	A-393-06	0.281	7.137
19098-0015	AA-1192-10	0.188	4.763	19123-0014	A-393-08	0.281	7.137
19098-0017	AA-1704-05	0.188	4.763	19123-0015	A-393-10	0.281	7.137
19098-0018	AA-1704-06	0.188	4.763	19123-0016	A-396-04	0.281	7.137
19098-0021	AA-1705-08	0.188	4.763	19123-0017	A-396-06	0.281	7.137
19098-0022	AA-1706-10	0.188	4.763	19123-0018	A-396-08	0.281	7.137
19098-0023	AA-1714-08	0.188	4.763	19124-0001	AA-3108-02	0.188	4.763
19098-0024	AA-1715-10	0.188	4.763	19124-0003	AA-3108-04	0.188	4.763
19098-0097	AA-1704-04	0.188	4.763	19124-0005	AA-315-04	0.188	4.763
19117-0015	A-115-04	0.281	7.137	19124-0007	AA-315-06	0.188	4.763
19117-0016	A-115-06	0.281	7.137	19124-0009	AA-315-08	0.188	4.763
19117-0018	A-115-08	0.281	7.137	19124-0011	AA-3461-04	0.188	4.763
19117-0020	A-115-10	0.281	7.137	19124-0012	AA-3461-06	0.188	4.763
19117-0023	A-190-06	0.281	7.137	19124-0013	AA-3461-08	0.188	4.763
19117-0024	A-190-08	0.281	7.137	19124-0014	AA-3461-10	0.188	4.763
19117-0025	A-190-10	0.281	7.137	19124-0015	AA-390-06	0.188	4.763
19117-0026	A-193-06	0.281	7.137	19124-0017	AA-390-08	0.188	4.763
19117-0027	A-193-08	0.281	7.137	19124-0019	AA-390-10	0.188	4.763

Wire Size: 18 – 22 AWG 0.80 – 0.35 mm ²				Wire Size: 18 – 22 AWG 0.80 – 0.35 mm ²			
Terminal No.	Terminal Eng No. (REF)	Wire Strip Length		Terminal No.	Terminal Eng No. (REF)	Wire Strip Length	
		In	mm			In	mm
19124-0021	AA-393-06	0.188	4.763	19135-0002	AA-3109-04	0.188	4.763
19124-0023	AA-393-08	0.188	4.763	19140-0030	A-134-04	0.281	7.137
19124-0025	AA-393-10	0.188	4.763	19140-0031	A-134-06	0.281	7.137
19124-0027	AA-396-04	0.188	4.763	19140-0033	A-134-08	0.281	7.137
19124-0029	AA-396-06	0.188	4.763	19140-0034	A-134-10	0.281	7.137
19124-0031	AA-396-08	0.188	4.763	19140-0035	A-135-06	0.281	7.137
19124-0074	AA-315-10	0.188	4.763	19140-0036	A-135-08	0.281	7.137
19128-0004	A-1118-06	0.281	7.137	19140-0037	A-135-10	0.281	7.137
19128-0006	A-1118-08	0.281	7.137	19140-0038	A-138-04	0.281	7.137
19128-0008	A-1461-04	0.281	7.137	19140-0040	A-138-06	0.281	7.137
19128-0010	A-1461-06	0.281	7.137	19141-0020	AA-135-06	0.188	4.763
19128-0012	A-1461-08	0.281	7.137	19141-0022	AA-135-08	0.188	4.763
19128-0013	A-1461-10	0.281	7.137	19141-0024	AA-135-10	0.188	4.763
19128-0035	A-191-06	0.281	7.137	19146-0004	A-338-04	0.281	7.137
19128-0036	A-191-08	0.281	7.137	19146-0005	A-338-06	0.281	7.137
19128-0037	A-191-10	0.281	7.137	19146-0007	A-391-06	0.281	7.137
19128-0038	A-194-06	0.281	7.137	19146-0008	A-391-08	0.281	7.137
19128-0039	A-194-08	0.281	7.137	19146-0009	A-391-10	0.281	7.137
19128-0040	A-194-10	0.281	7.137	19146-0010	A-394-06	0.281	7.137
19128-0041	A-197-04	0.281	7.137	19146-0011	A-394-08	0.281	7.137
19128-0042	A-197-06	0.281	7.137	19146-0012	A-394-10	0.281	7.137
19128-0043	A-197-08	0.281	7.137	19146-0013	A-397-04	0.281	7.137
19129-0023	AA-197-08	0.188	4.763	19146-0014	A-397-06	0.281	7.137
19129-0025	AA-197-06	0.188	4.763	19146-0015	A-397-08	0.281	7.137
19129-0027	AA-197-04	0.188	4.763	19147-0002	AA-3118-06	0.188	4.763
19129-0029	AA-191-10	0.188	4.763	19147-0003	AA-3118-08	0.188	4.763
19129-0031	AA-191-08	0.188	4.763	19147-0004	AA-334-04	0.188	4.763
19129-0033	AA-191-06	0.188	4.763	19147-0006	AA-334-06	0.188	4.763
19129-0035	AA-194-10	0.188	4.763	19147-0008	AA-334-08	0.188	4.763
19129-0036	AA-194-08	0.188	4.763	19147-0010	AA-334-10	0.188	4.763
19129-0037	AA-194-06	0.188	4.763	19147-0011	AA-335-06	0.188	4.763
19129-0039	AA-138-06	0.188	4.763	19147-0013	AA-335-08	0.188	4.763
19129-0041	AA-138-04	0.188	4.763	19147-0015	AA-335-10	0.188	4.763
19129-0043	AA-134-10	0.188	4.763	19147-0017	AA-338-04	0.188	4.763
19129-0045	AA-134-08	0.188	4.763	19147-0019	AA-338-06	0.188	4.763
19129-0047	AA-134-06	0.188	4.763	19147-0022	AA-391-06	0.188	4.763
19129-0048	AA-134-04	0.188	4.763	19147-0024	AA-391-08	0.188	4.763
19129-0049	AA-1118-08	0.188	4.763	19147-0026	AA-391-10	0.188	4.763
19129-0051	AA-1118-06	0.188	4.763	19147-0028	AA-394-06	0.188	4.763
19129-0053	AA-1109-04	0.188	4.763	19147-0030	AA-394-08	0.188	4.763
19129-0055	AA-1109-02	0.188	4.763	19147-0032	AA-394-10	0.188	4.763
19134-0002	A-3118-06	0.281	7.137	19147-0034	AA-397-04	0.188	4.763
19134-0003	A-3118-08	0.281	7.137	19147-0036	AA-397-06	0.188	4.763
19134-0004	A-334-04	0.281	7.137	19147-0038	AA-397-08	0.188	4.763
19134-0005	A-334-06	0.281	7.137	19170-0001	A-110-06	0.281	7.137
19134-0006	A-334-08	0.281	7.137	19170-0003	A-110-08	0.281	7.137
19134-0007	A-334-10	0.281	7.137	19170-0005	A-110-10	0.281	7.137
19134-0008	A-335-06	0.281	7.137	19172-0001	A-310-06	0.281	7.137
19134-0009	A-335-08	0.281	7.137	19172-0003	A-310-08	0.281	7.137
19134-0010	A-335-10	0.281	7.137	19172-0005	A-310-10	0.281	7.137
19135-0001	AA-3109-02	0.188	4.763	19178-0002	AA-110-06	0.188	4.763

Wire Size: 18 – 22 AWG 0.80 – 0.35 mm ²			
Terminal No.	Terminal Eng No. (REF)	Wire Strip Length	
		In	mm
19178-0004	AA-110-08	0.188	4.763
19178-0006	AA-110-10	0.188	4.763
19180-0002	AA-310-06	0.188	4.763
19180-0003	AA-310-08	0.188	4.763
19180-0005	AA-310-10	0.188	4.763
19189-0002	A-145	0.234	5.944
19189-0003	A-145-B	0.234	5.944
19189-0005	A-L145	0.281	7.137
19193-0007	AA-320-04	0.188	4.763
19193-0009	AA-320-06	0.188	4.763
19193-0012	AA-321-06	0.188	4.763
19193-0014	AA-321-08	0.188	4.763
19193-0016	AA-321-10	0.188	4.763
19193-0019	AA-322-10	0.188	4.763
19193-0021	AA-322-14	0.188	4.763
19193-0023	AA-322-56	0.188	4.763
19193-0025	AA-326-10	0.188	4.763
19193-0026	AA-326-14	0.188	4.763
19193-0028	AA-326-38	0.188	4.763
19193-0030	AA-326-56	0.188	4.763
19193-0032	AA-332-04	0.188	4.763
19193-0034	AA-332-06	0.188	4.763
19193-0036	AA-332-08	0.188	4.763
19193-0041	AA-333-10	0.188	4.763
19193-0044	AA-T-320-06	0.188	4.763
19193-0049	AA-T-332-06	0.188	4.763
19193-0394	AA-3111-02	0.188	4.763
19193-0396	AA-3111-04	0.188	4.763
19193-0398	AA-320-02	0.188	4.763
19193-0448	AA-T-322-14	0.188	4.763
19193-0613	AA-T-333-10	0.188	4.763
19203-0008	A-S-132-04	0.281	7.137
19203-0015	A-S-133-10	0.281	7.137
19203-0144	A-S-122-14	0.281	7.137
19203-0145	A-S-132-06	0.281	7.137
19203-0146	A-S-132-08	0.281	7.137
19203-0164	A-S-145	0.250	6.350
19203-0165	A-T-302	0.250	6.350
19203-0166	A-T-345	0.281	7.137
19203-0204	AA-U-132-06	0.188	4.763
19203-0205	AA-U-132-08	0.188	4.763
19203-0206	AA-U-133-10	0.188	4.763
19203-0221	AA-T-320-04	0.188	4.763
19203-0222	AA-T-322-56	0.188	4.763
19203-0226	A-S-120-06	0.281	7.137
19203-0229	A-S-122-56	0.281	7.137
19203-0301	A-S-126-38	0.281	7.137
19204-0001	A-1XC	0.281	7.137
19204-0002	A-1YC	0.281	7.137
19204-0005	A-3YC	0.281	7.137
19204-0006	A-3XC	0.281	7.137

Wire Size: 18 – 22 AWG 0.80 – 0.35 mm ²			
Terminal No.	Terminal Eng No. (REF)	Wire Strip Length	
		In	mm
19207-0001	AS-302	0.281	7.137
19211-0003	WP-1614	0.188	4.763
19215-0009	AS-345	0.281	7.137

Wire Size: 14 – 16 AWG 2.00 – 1.30 mm ²			
Terminal No.	Terminal Eng No. (REF)	Wire Strip Length	
		In	mm
19033-0005	B-179	0.188	4.763
19033-0007	B-189	0.188	4.763
19044-0028	B-137-04	0.281	7.137
19044-0030	B-137-06	0.281	7.137
19044-0031	B-137-08	0.281	7.137
19044-0032	B-137-10	0.281	7.137
19044-0033	B-139-04	0.281	7.137
19044-0035	B-139-06	0.281	7.137
19044-0037	B-139-08	0.281	7.137
19044-0039	B-139-10	0.281	7.137
19044-0137	B-101-12HD	0.281	7.137
19044-0139	B-101-14HD	0.281	7.137
19044-0140	B-101-38HD	0.281	7.137
19044-0141	B-101-56HD	0.281	7.137
19044-0142	B-101-76HD	0.281	7.137
19044-0143	B-118-10	0.281	7.137
19044-0143	BB-118-10	0.188	4.763
19044-0144	B-118-14	0.281	7.137
19044-0144	BB-118-14	0.188	4.763
19044-0146	B-118-38	0.281	7.137
19044-0146	BB-118-38	0.188	4.763
19044-0148	B-118-56	0.281	7.137
19044-0148	BB-118-56	0.188	4.763
19044-0149	B-123-02	0.281	7.137
19044-0150	B-123-04	0.281	7.137
19044-0152	B-123-06	0.281	7.137
19044-0154	B-123-08	0.281	7.137
19044-0156	B-125-10	0.281	7.137
19044-0158	B-125-14	0.281	7.137
19044-0160	B-125-56	0.281	7.137
19056-0053	B-318-10	0.281	7.137
19056-0055	B-318-14	0.281	7.137
19056-0057	B-318-38	0.281	7.137
19056-0059	B-318-56	0.281	7.137
19056-0061	B-323-02	0.281	7.137
19056-0063	B-323-04	0.281	7.137
19056-0065	B-323-06	0.281	7.137
19056-0068	B-323-08	0.281	7.137
19056-0070	B-325-10	0.281	7.137
19056-0072	B-325-14	0.281	7.137
19056-0075	B-325-56	0.281	7.137
19056-0102	B-337-04	0.281	7.137
19056-0104	B-337-06	0.281	7.137

Wire Size: 14 – 16 AWG 2.00 – 1.30 mm ²				Wire Size: 14 – 16 AWG 2.00 – 1.30 mm ²			
Terminal No.	Terminal Eng No. (REF)	Wire Strip Length		Terminal No.	Terminal Eng No. (REF)	Wire Strip Length	
		In	mm			In	mm
19056-0106	B-337-08	0.281	7.137	19087-0104	BB-182-06	0.188	4.763
19056-0109	B-337-10	0.281	7.137	19087-0106	BB-182-08	0.188	4.763
19056-0112	B-339-04	0.281	7.137	19087-0108	BB-182-10	0.188	4.763
19056-0114	B-339-06	0.281	7.137	19087-0113	BB-185-06	0.188	4.763
19056-0116	B-339-08	0.281	7.137	19087-0115	BB-185-08	0.188	4.763
19056-0118	B-339-10	0.281	7.137	19087-0117	BB-185-10	0.188	4.763
19056-0141	B-323-06R90	0.281	7.137	19087-0122	BB-188-04	0.188	4.763
19069-0098	BB-123-02	0.188	4.763	19087-0124	BB-188-06	0.188	4.763
19069-0099	BB-123-04	0.188	4.763	19087-0126	BB-188-08	0.188	4.763
19069-0101	BB-123-06	0.188	4.763	19087-0128	BB-188-10	0.188	4.763
19069-0103	BB-123-08	0.188	4.763	19088-0020	B-308-04	0.281	7.137
19069-0105	BB-125-10	0.188	4.763	19088-0021	B-308-06	0.281	7.137
19069-0107	BB-125-14	0.188	4.763	19088-0024	B-309-06	0.281	7.137
19069-0109	BB-125-56	0.188	4.763	19088-0025	B-309-08	0.281	7.137
19069-0111	BB-137-04	0.188	4.763	19088-0026	B-309-10	0.281	7.137
19069-0112	BB-137-06	0.188	4.763	19088-0027	B-313-04	0.281	7.137
19069-0114	BB-137-08	0.188	4.763	19088-0028	B-313-06	0.281	7.137
19069-0116	BB-137-10	0.188	4.763	19088-0029	B-313-08	0.281	7.137
19069-0119	BB-139-04	0.188	4.763	19088-0034	B-382-06	0.281	7.137
19069-0120	BB-139-06	0.188	4.763	19088-0035	B-382-08	0.281	7.137
19069-0121	BB-139-08	0.188	4.763	19088-0036	B-382-10	0.281	7.137
19069-0123	BB-139-10	0.188	4.763	19088-0037	B-385-06	0.281	7.137
19079-0007	B-1006-MS	0.281	7.137	19088-0038	B-385-08	0.281	7.137
19086-0065	B-108-04	0.281	7.137	19088-0039	B-385-10	0.281	7.137
19086-0066	B-108-06	0.281	7.137	19088-0040	B-388-04	0.281	7.137
19086-0068	B-108-08	0.281	7.137	19088-0041	B-388-06	0.281	7.137
19086-0070	B-109-06	0.281	7.137	19088-0042	B-388-08	0.281	7.137
19086-0071	B-109-08	0.281	7.137	19088-0043	B-388-10	0.281	7.137
19086-0072	B-109-10	0.281	7.137	19093-0039	BB-313-04	0.188	4.763
19086-0073	B-113-04	0.281	7.137	19093-0041	BB-313-06	0.188	4.763
19086-0073	BB-113-04	0.188	4.763	19093-0043	BB-313-08	0.188	4.763
19086-0074	B-113-06	0.281	7.137	19093-0045	BB-382-06	0.188	4.763
19086-0074	BB-113-06	0.188	4.763	19093-0047	BB-382-08	0.188	4.763
19086-0075	B-113-08	0.281	7.137	19093-0049	BB-382-10	0.188	4.763
19086-0075	BB-113-08	0.188	4.763	19093-0051	BB-385-06	0.188	4.763
19086-0076	B-182-06	0.281	7.137	19093-0053	BB-385-08	0.188	4.763
19086-0077	B-182-08	0.281	7.137	19093-0055	BB-385-10	0.188	4.763
19086-0078	B-182-10	0.281	7.137	19093-0057	BB-388-04	0.188	4.763
19086-0079	B-185-06	0.281	7.137	19093-0059	BB-388-06	0.188	4.763
19086-0080	B-186-08	0.281	7.137	19093-0061	BB-388-08	0.188	4.763
19086-0081	B-185-10	0.281	7.137	19093-0063	BB-388-10	0.188	4.763
19086-0082	B-188-04	0.281	7.137	19098-0034	BB-1193-06	0.188	4.763
19086-0083	B-188-06	0.281	7.137	19098-0036	BB-1194-08	0.188	4.763
19086-0084	B-188-08	0.281	7.137	19098-0038	BB-1195-10	0.188	4.763
19086-0144	B-L80-08	0.296	7.518	19098-0041	BB-1707-05	0.188	4.763
19086-0145	B-L81-06	0.296	7.518	19098-0043	BB-1707-06	0.188	4.763
19086-0146	B-L82-08	0.296	7.518	19098-0047	BB-1716-08	0.188	4.763
19086-0147	B-L83-05	0.296	7.518	19098-0049	BB-1717-10	0.188	4.763
19086-0148	B-L84-06	0.296	7.518	19117-0048	B-116-04	0.281	7.137
19086-0149	B-L85-04	0.296	7.518	19117-0048	BB-116-04	0.188	4.763
19086-0150	B-L86-04	0.296	7.518	19117-0052	B-116-10	0.281	7.137

Wire Size: 14 – 16 AWG 2.00 – 1.30 mm ²				Wire Size: 14 – 16 AWG 2.00 – 1.30 mm ²			
Terminal No.	Terminal Eng No. (REF)	Wire Strip Length		Terminal No.	Terminal Eng No. (REF)	Wire Strip Length	
		In	mm			In	mm
19117-0052	BB-116-10	0.188	4.763	19124-0043	BB-380-06	0.188	4.763
19117-0058	B-1491-06	0.281	7.137	19124-0045	BB-380-08	0.188	4.763
19117-0059	B-1491-08	0.281	7.137	19124-0047	BB-380-10	0.188	4.763
19117-0060	B-1491-10	0.281	7.137	19124-0049	BB-383-06	0.188	4.763
19117-0061	B-180-06	0.281	7.137	19124-0051	BB-383-08	0.188	4.763
19117-0062	B-180-08	0.281	7.137	19124-0053	BB-383-10	0.188	4.763
19117-0063	B-180-10	0.281	7.137	19124-0055	BB-386-04	0.188	4.763
19117-0064	B-183-06	0.281	7.137	19124-0057	BB-386-06	0.188	4.763
19117-0065	B-183-08	0.281	7.137	19124-0059	BB-386-08	0.188	4.763
19117-0066	B-183-10	0.281	7.137	19124-0075	BB-316-10	0.188	4.763
19117-0068	B-186-04	0.281	7.137	19128-0014	B-1471-04	0.281	7.137
19117-0069	B-186-06	0.281	7.137	19128-0016	B-1471-06	0.281	7.137
19117-0070	B-186-08	0.281	7.137	19128-0021	B-1781-06	0.281	7.137
19117-0083	B-116-06	0.281	7.137	19128-0023	B-1781-08	0.281	7.137
19117-0083	BB-116-06	0.188	4.763	19128-0025	B-1781-10	0.281	7.137
19117-0084	B-116-08	0.281	7.137	19128-0026	B-181-06	0.281	7.137
19117-0084	BB-116-08	0.188	4.763	19128-0027	B-181-08	0.281	7.137
19118-0060	BB-1491-06	0.188	4.763	19128-0028	B-181-10	0.281	7.137
19118-0061	BB-1491-08	0.188	4.763	19128-0029	B-184-06	0.281	7.137
19118-0062	BB-1491-10	0.188	4.763	19128-0030	B-184-08	0.281	7.137
19118-0063	BB-180-06	0.188	4.763	19128-0031	B-184-10	0.281	7.137
19118-0064	BB-180-08	0.188	4.763	19128-0032	B-187-04	0.281	7.137
19118-0065	BB-180-10	0.188	4.763	19128-0033	B-187-06	0.281	7.137
19118-0066	BB-183-06	0.188	4.763	19128-0034	B-187-08	0.281	7.137
19118-0067	BB-183-08	0.188	4.763	19129-0002	BB-181-10	0.188	4.763
19118-0068	BB-183-10	0.188	4.763	19129-0003	BB-181-08	0.188	4.763
19118-0070	BB-186-04	0.188	4.763	19129-0004	BB-181-06	0.188	4.763
19118-0071	BB-186-06	0.188	4.763	19129-0012	BB-187-08	0.188	4.763
19118-0072	BB-186-08	0.188	4.763	19129-0013	BB-187-06	0.188	4.763
19123-0019	B-316-04	0.281	7.137	19129-0014	BB-187-04	0.188	4.763
19123-0020	B-316-06	0.281	7.137	19129-0015	BB-184-10	0.188	4.763
19123-0021	B-316-08	0.281	7.137	19129-0016	BB-184-08	0.188	4.763
19123-0022	B-316-10	0.281	7.137	19129-0017	BB-184-06	0.188	4.763
19123-0027	B-3491-06	0.281	7.137	19129-0020	BB-1781-10	0.188	4.763
19123-0028	B-3491-08	0.281	7.137	19129-0022	BB-1781-08	0.188	4.763
19123-0029	B-3491-10	0.281	7.137	19129-0024	BB-1781-06	0.188	4.763
19123-0030	B-380-06	0.281	7.137	19129-0026	BB-1781-04	0.188	4.763
19123-0031	B-380-08	0.281	7.137	19129-0030	BB-1471-06	0.188	4.763
19123-0032	B-380-10	0.281	7.137	19129-0032	BB-1471-04	0.188	4.763
19123-0033	B-383-06	0.281	7.137	19140-0085	B-107-04	0.281	7.137
19123-0034	B-383-08	0.281	7.137	19140-0085	BB-107-04	0.188	4.763
19123-0035	B-383-10	0.281	7.137	19140-0086	B-107-06	0.281	7.137
19123-0036	B-386-04	0.281	7.137	19140-0086	BB-107-06	0.188	4.763
19123-0037	B-386-06	0.281	7.137	19140-0087	B-124-04	0.281	7.137
19123-0038	B-386-08	0.281	7.137	19140-0088	B-124-06	0.281	7.137
19124-0033	BB-316-04	0.188	4.763	19140-0089	B-124-08	0.281	7.137
19124-0035	BB-316-06	0.188	4.763	19140-0090	B-127-06	0.281	7.137
19124-0037	BB-316-08	0.188	4.763	19140-0091	B-127-08	0.281	7.137
19124-0040	BB-3491-06	0.188	4.763	19140-0093	B-127-10	0.281	7.137
19124-0041	BB-3491-08	0.188	4.763	19141-0054	BB-124-04	0.188	4.763
19124-0042	BB-3491-10	0.188	4.763	19141-0056	BB-124-06	0.188	4.763

Wire Size: 14 – 16 AWG 2.00 – 1.30 mm ²				Wire Size: 14 – 16 AWG 2.00 – 1.30 mm ²			
Terminal No.	Terminal Eng No. (REF)	Wire Strip Length		Terminal No.	Terminal Eng No. (REF)	Wire Strip Length	
		In	mm			In	mm
19141-0058	BB-124-08	0.188	4.763	19170-0007	BB-119-06	0.188	4.763
19141-0061	BB-127-06	0.188	4.763	19170-0009	B-119-08	0.281	7.137
19141-0063	BB-127-08	0.188	4.763	19170-0009	BB-119-08	0.188	4.763
19141-0065	BB-127-10	0.188	4.763	19170-0011	B-119-10	0.281	7.137
19146-0016	B-307-04	0.281	7.137	19170-0011	BB-119-10	0.188	4.763
19146-0017	B-307-06	0.281	7.137	19172-0007	B-319-06	0.281	7.137
19146-0018	B-324-04	0.281	7.137	19172-0009	B-319-08	0.281	7.137
19146-0019	B-324-06	0.281	7.137	19172-0011	B-319-10	0.281	7.137
19146-0021	B-324-08	0.281	7.137	19180-0007	BB-319-06	0.188	4.763
19146-0024	B-327-06	0.281	7.137	19180-0009	BB-319-08	0.188	4.763
19146-0025	B-327-08	0.281	7.137	19180-0011	BB-319-10	0.188	4.763
19146-0029	B-3471-04	0.281	7.137	19189-0008	B-131	0.234	5.944
19146-0030	B-3471-06	0.281	7.137	19189-0009	B-131-B	0.234	5.944
19146-0034	B-3781-04	0.281	7.137	19189-0012	B-L131	0.281	7.137
19146-0035	B-3781-06	0.281	7.137	19193-0053	BB-318-10	0.188	4.763
19146-0036	B-3781-08	0.281	7.137	19193-0055	BB-318-14	0.188	4.763
19146-0037	B-3781-10	0.281	7.137	19193-0057	BB-318-38	0.188	4.763
19146-0038	B-381-06	0.281	7.137	19193-0060	BB-318-56	0.188	4.763
19146-0039	B-381-08	0.281	7.137	19193-0062	BB-323-02	0.188	4.763
19146-0040	B-381-10	0.281	7.137	19193-0064	BB-323-04	0.188	4.763
19146-0041	B-384-06	0.281	7.137	19193-0066	BB-323-06	0.188	4.763
19146-0042	B-384-08	0.281	7.137	19193-0068	BB-323-08	0.188	4.763
19146-0043	B-384-10	0.281	7.137	19193-0070	BB-325-10	0.188	4.763
19146-0044	B-387-04	0.281	7.137	19193-0072	BB-325-14	0.188	4.763
19146-0045	B-387-06	0.281	7.137	19193-0074	BB-325-56	0.188	4.763
19146-0046	B-387-08	0.281	7.137	19193-0076	BB-337-04	0.188	4.763
19146-0096	B-327-10	0.281	7.137	19193-0078	BB-337-06	0.188	4.763
19147-0040	BB-307-04	0.188	4.763	19193-0080	BB-337-08	0.188	4.763
19147-0042	BB-307-06	0.188	4.763	19193-0082	BB-337-10	0.188	4.763
19147-0044	BB-324-04	0.188	4.763	19193-0085	BB-339-04	0.188	4.763
19147-0046	BB-324-06	0.188	4.763	19193-0087	BB-339-06	0.188	4.763
19147-0048	BB-324-08	0.188	4.763	19193-0089	BB-339-08	0.188	4.763
19147-0050	BB-327-06	0.188	4.763	19193-0091	BB-339-10	0.188	4.763
19147-0052	BB-327-08	0.188	4.763	19202-0023	B-N-131	0.234	5.944
19147-0054	BB-327-10	0.188	4.763	19203-0042	B-S-123-06	0.281	7.137
19147-0056	BB-3471-04	0.188	4.763	19203-0044	B-S-125-14	0.281	7.137
19147-0057	BB-3471-06	0.188	4.763	19203-0047	B-S-137-06	0.296	7.540
19147-0058	BB-3781-04	0.188	4.763	19203-0049	B-S-137-08	0.281	7.137
19147-0059	BB-3781-06	0.188	4.763	19203-0051	B-S-137-10	0.281	7.137
19147-0061	BB-3781-08	0.188	4.763	19203-0061	BB-T-337-08	0.188	4.763
19147-0062	BB-3781-10	0.188	4.763	19203-0063	BB-T-337-10	0.188	4.763
19147-0064	BB-381-06	0.188	4.763	19203-0070	BB-T-437-06	0.250	6.350
19147-0066	BB-381-08	0.188	4.763	19203-0072	BB-T-437-08	0.250	6.350
19147-0068	BB-381-10	0.188	4.763	19203-0074	BB-T-437-10	0.250	6.350
19147-0070	BB-384-06	0.188	4.763	19203-0077	BB-U-123-06	0.188	4.763
19147-0072	BB-384-08	0.188	4.763	19203-0079	BB-U-125-14	0.188	4.763
19147-0074	BB-384-10	0.188	4.763	19203-0083	BB-U-137-08	0.188	4.763
19147-0076	BB-387-04	0.188	4.763	19203-0085	BB-U-137-10	0.188	4.763
19147-0078	BB-387-06	0.188	4.763	19203-0147	BB-T-323-06	0.188	4.763
19147-0080	BB-387-08	0.188	4.763	19203-0148	BB-T-325-14	0.188	4.763
19170-0007	B-119-06	0.281	7.137	19203-0149	BB-T-337-06	0.188	4.763

Wire Size: 14 – 16 AWG 2.00 – 1.30 mm ²			
Terminal No.	Terminal Eng No. (REF)	Wire Strip Length	
		In	mm
19203-0150	BB-U-137-06	0.188	4.763
19203-0170	B-S-131	0.296	7.540
19203-0171	B-T-331	0.296	7.540
19203-0172	B-T-304	0.281	7.137
19203-0202	B-S-127-10	0.281	7.137
19203-0223	BB-T-318-38	0.188	4.763
19203-0233	B-S-125-56	0.281	7.137
19203-0274	BB-U-125-56	0.188	4.763
19203-0302	B-S-118-38	0.281	7.137
19204-0011	B-1XC	0.281	7.137
19204-0012	B-1YC	0.281	7.137
19204-0015	B-3XC	0.281	7.137
19204-0016	B-3YC	0.281	7.137
19205-0001	BS-304	0.281	7.137
19208-0001	B-104	0.281	7.137
19211-0005	WP-1614	0.188	4.763
19215-0013	BA-331	0.281	7.137
19215-0018	BS-331	0.281	7.137
19022-0018	MCT-1	0.281	7.137
19022-0021	MCT-1-N	0.281	7.137
19022-0027	MMCT-1	0.187	4.760

HEAVY DUTY Wire Size: 14 – 16 AWG 2.00 – 1.30 mm ² Also suitable for 12 AWG 3.00 mm ² Use 10-12 Pocket (YELLOW)			
Terminal No.	Terminal Eng No. (REF)	Wire Strip Length	
		In	mm
19044-0137	B-101-12HD	0.281	7.137
19044-0139	B-101-14HD	0.281	7.137
19044-0140	B-101-38HD	0.281	7.137
19044-0141	B-101-56HD	0.281	7.137
19044-0142	B-101-76HD	0.281	7.137
19044-0161	B-128-06HD	0.281	7.137
19044-0162	B-128-08HD	0.281	7.137
19044-0163	B-128-10HD	0.281	7.137
19044-0166	B-130-10HD	0.281	7.137
19044-0167	B-130-14HD	0.281	7.137
19044-0168	B-130-56HD	0.281	7.137
19044-0172	B-136-04HD	0.281	7.137
19044-0173	B-136-06HD	0.281	7.137
19044-0174	B-136-08HD	0.281	7.137
19044-0180	B-140-10HD	0.281	7.137
19044-0182	B-140-14HD	0.281	7.137
19044-0184	B-140-38HD	0.281	7.137
19044-0186	B-140-56HD	0.281	7.137
19056-0049	B-301-56HD	0.281	7.137
19056-0079	B-328-06HD	0.281	7.137
19056-0081	B-328-08HD	0.281	7.137

HEAVY DUTY Wire Size: 14 – 16 AWG 2.00 – 1.30 mm ² Also suitable for 12 AWG 3.00 mm ² Use 10-12 Pocket (YELLOW)			
Terminal No.	Terminal Eng No. (REF)	Wire Strip Length	
		In	mm
19056-0083	B-328-10HD	0.281	7.137
19056-0085	B-330-10HD	0.281	7.137
19056-0087	B-330-14HD	0.281	7.137
19056-0089	B-330-56HD	0.281	7.137
19056-0095	B-336-04HD	0.281	7.137
19056-0121	B-340-10HD	0.281	7.137
19056-0125	B-340-38HD	0.281	7.137
19117-0054	B-117-06HD	0.281	7.137
19117-0055	B-117-08HD	0.281	7.137
19117-0056	B-117-10HD	0.281	7.137
19123-0023	B-317-06HD	0.281	7.137
19123-0025	B-317-10HD	0.281	7.137
19140-0095	B-141-06HD	0.281	7.137
19140-0097	B-141-08HD	0.281	7.137
19140-0098	B-141-10HD	0.281	7.137
19140-0099	B-168-10HD	0.281	7.137
19140-0100	B-168-14HD	0.281	7.137
19140-0101	B-168-56HD	0.281	7.137
19146-0027	B-341-08HD	0.281	7.137
19146-0031	B-368-10HD	0.281	7.137
19146-0033	B-368-56HD	0.281	7.137

Wire Size: 10 – 12 AWG 5.00 – 3.00 mm ²			
Terminal No.	Terminal Eng No. (REF)	Wire Strip Length	
		In	mm
19000-0303	C-128-08R90	0.281	7.137
19000-0304	C-128-10R90	0.281	7.137
19069-0180	C-030-14	0.281	7.137
19069-0192	C-101-12	0.281	7.137
19069-0195	C-101-14	0.281	7.137
19069-0196	C-101-38	0.281	7.137
19069-0197	C-101-56	0.281	7.137
19069-0198	C-101-76	0.281	7.137
19069-0200	C-128-04	0.281	7.137
19069-0202	C-128-06	0.281	7.137
19069-0205	C-128-08	0.281	7.137
19069-0209	C-128-10	0.281	7.137
19069-0217	C-130-10	0.281	7.137
19069-0219	C-130-14	0.281	7.137
19069-0222	C-130-38	0.281	7.137
19069-0223	C-130-56	0.281	7.137
19069-0229	C-136-04	0.281	7.137
19069-0230	C-136-06	0.281	7.137
19069-0233	C-136-08	0.281	7.137
19069-0234	C-136-08R90	0.281	7.137
19069-0236	C-140-10	0.281	7.137

Wire Size: 10 – 12 AWG 5.00 – 3.00 mm ²				Wire Size: 10 – 12 AWG 5.00 – 3.00 mm ²			
Terminal No.	Terminal Eng No. (REF)	Wire Strip Length		Terminal No.	Terminal Eng No. (REF)	Wire Strip Length	
		In	mm			In	mm
19069-0238	C-140-14	0.281	7.137	19147-0096	C-341-10	0.281	7.137
19069-0241	C-140-38	0.281	7.137	19147-0099	C-3481-10	0.281	7.137
19069-0244	C-140-56	0.281	7.137	19147-0100	C-368-10	0.281	7.137
19079-0011	C-1006-MS	0.281	7.137	19147-0101	C-368-14	0.281	7.137
19087-0145	C-1103-08	0.281	7.137	19147-0103	C-368-56	0.281	7.137
19087-0147	C-1106-06	0.281	7.137	19147-0105	C-341-08	0.281	7.137
19087-0149	C-112-06	0.281	7.137	19178-0014	C-111-06	0.281	7.137
19087-0151	C-112-08	0.281	7.137	19178-0016	C-111-08	0.281	7.137
19087-0153	C-112-10	0.281	7.137	19178-0018	C-111-10	0.281	7.137
19093-0067	C-3106-06	0.281	7.137	19178-0020	C-199-14	0.281	7.137
19093-0069	C-312-06	0.281	7.137	19178-0021	C-199-56	0.281	7.137
19093-0071	C-312-08	0.281	7.137	19180-0013	C-311-06	0.281	7.137
19093-0073	C-312-10	0.281	7.137	19180-0015	C-311-08	0.281	7.137
19098-0061	C-1196-06	0.281	7.137	19180-0017	C-311-10	0.281	7.137
19098-0063	C-1197-08	0.281	7.137	19180-0019	C-399-14	0.281	7.137
19098-0065	C-1198-10	0.281	7.137	19189-0015	C-146	0.234	5.950
19098-0067	C-1199-14	0.281	7.137	19189-0016	C-146-B	0.234	5.950
19098-0068	C-1710-05	0.281	7.137	19189-0018	C-L146	0.359	9.119
19098-0069	C-1710-06	0.281	7.137	19193-0096	C-301-14	0.281	7.137
19098-0073	C-1718-08	0.281	7.137	19193-0097	C-301-38	0.281	7.137
19098-0074	C-1719-10	0.281	7.137	19193-0098	C-301-56	0.281	7.137
19118-0078	C-1101-08	0.281	7.137	19193-0099	C-301-76	0.281	7.137
19118-0079	C-1104-06	0.281	7.137	19193-0101	C-328-04	0.281	7.137
19118-0080	C-1104-08	0.281	7.137	19193-0103	C-328-06	0.281	7.137
19118-0082	C-1104-10	0.281	7.137	19193-0106	C-328-08	0.281	7.137
19118-0084	C-117-06	0.281	7.137	19193-0112	C-328-209	0.281	7.137
19118-0086	C-117-08	0.281	7.137	19193-0114	C-330-10	0.281	7.137
19118-0088	C-117-10	0.281	7.137	19193-0116	C-330-14	0.281	7.137
19124-0061	C-3101-08	0.281	7.137	19193-0126	C-336-04	0.281	7.137
19124-0063	C-3104-06	0.281	7.137	19193-0130	C-336-08	0.281	7.137
19124-0065	C-3104-08	0.281	7.137	19193-0132	C-340-10	0.281	7.137
19124-0066	C-3104-10	0.281	7.137	19193-0134	C-340-14	0.281	7.137
19124-0067	C-317-06	0.281	7.137	19193-0141	C-340-56	0.281	7.137
19124-0069	C-317-08	0.281	7.137	19193-0532	C-328-10R90	0.281	7.137
19124-0071	C-317-10	0.281	7.137	19203-0091	C-S-128-06	0.281	7.137
19129-0001	C-1481-10	0.281	7.137	19203-0099	C-340-38	0.281	7.144
19129-0005	C-1105-10	0.281	7.137	19203-0113	C-U-128-10	0.281	7.137
19129-0007	C-1105-08	0.281	7.137	19203-0151	C-S-128-08	0.281	7.137
19129-0008	C-1105-06	0.281	7.137	19203-0152	C-S-130-14	0.281	7.137
19129-0010	C-1102-08	0.281	7.137	19203-0153	C-S-130-56	0.281	7.137
19141-0081	C-141-06	0.281	7.137	19203-0154	C-S-140-38	0.281	7.137
19141-0083	C-141-08	0.281	7.137	19203-0155	C-T-328-06	0.281	7.137
19141-0085	C-141-10	0.281	7.137	19203-0156	C-330-56	0.281	7.144
19141-0087	C-168-10	0.281	7.137	19203-0157	C-T-330-56	0.281	7.137
19141-0088	C-168-14	0.281	7.137	19203-0158	C-T-328-10	0.281	7.144
19141-0090	C-168-56	0.281	7.137	19203-0158	C-T-340-38	0.281	7.137
19147-0083	C-3102-08	0.281	7.137	19203-0159	C-U-128-06	0.281	7.137
19147-0086	C-3105-06	0.281	7.137	19203-0160	C-U-128-08	0.281	7.137
19147-0088	C-3105-08	0.281	7.137	19203-0161	C-U-130-14	0.281	7.137
19147-0090	C-3105-10	0.281	7.137	19203-0162	C-U-130-56	0.281	7.137
19147-0092	C-341-06	0.281	7.137	19203-0163	C-U-140-38	0.281	7.137

Wire Size: 10 – 12 AWG 5.00 – 3.00 mm ²			
Terminal No.	Terminal Eng No. (REF)	Wire Strip Length	
		In	mm
19203-0167	C-S-146	0.234	5.950
19203-0169	C-T-303	0.281	7.140
19203-0182	C-T-328-08	0.281	7.144
19203-0182	C-T-330-14	0.281	7.137
19203-0183	C-T-346	0.359	9.119
19203-0224	C-T-430-56	0.375	9.520
19203-0228	C-S-128-04	0.281	7.137
19203-0235	C-S-141-10	0.281	7.137
19203-0236	C-T-428-08	0.375	9.520
19203-0236	C-T-428-08	0.375	9.520
19203-0237	C-U-428-10	0.375	9.520
19203-0276	C-T-430-14	0.375	9.520
19203-0389	C-S-128-10	0.281	7.137
19204-0023	C-1XC	0.281	7.137
19204-0024	C-1YC	0.281	7.137
19204-0027	C-3XC	0.281	7.137
19204-0028	C-3YC	0.281	7.137
19205-0003	CS-303	0.281	7.137

Wire Size: 10 – 12 AWG 5.00 – 3.00 mm ²			
Terminal No.	Terminal Eng No. (REF)	Wire Strip Length	
		In	mm
19208-0002	C-103	0.281	7.137
19211-0001	WP-1210	0.281	7.144
19215-0023	CB-346	0.359	9.119
19215-0028	CS-346	0.359	9.120

MILITARY Wire Size: 10 – 12 AWG 5.00 – 3.00 mm ²			
Terminal No.	Terminal Eng No. (REF)	Wire Strip Length	
		In	mm
19193-0094	C-301-12	0.281	7.137
19193-0109	C-328-10	0.281	7.137
19193-0120	C-330-56	0.281	7.137
19193-0128	C-336-06	0.281	7.137
19193-0137	C-340-38	0.281	7.137

Operation

Refer to the instruction manual for the 19279-0001 (AT-200) for mounting this crimp tool head.

Crimping Terminals

1. Adjust the locator up or down until the terminal being run sits flat and straight in the tool.
2. Insert the wire into the terminal. Push up on the locator blade and insert the terminal and wire into the proper nest with the barrel up and against the locator bar. Release the locator blade to hold the terminal in position. See Figure 1. Locator may be raised or lowered so terminal sits flat and straight in tool. The locator must be removed to run splices.

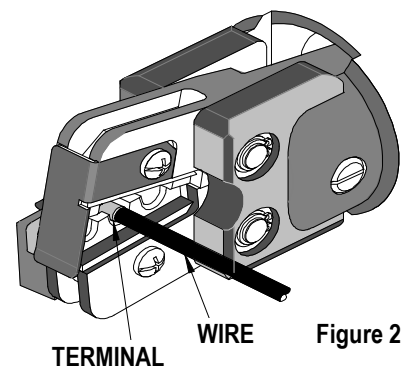

Caution: Never operate this tool without the supplied safety shield in place. Never place fingers in the tool nests.

3. Push on the wire to assure it is fully seated in the terminal. See Figure 2 and 3. The wires end should butt against the wire stop position of the locator. Cycle the tool.
4. Lift the locator blade or wire stop and remove the crimped terminal. Inspect for proper crimp location. Locator is adjustable up and down to keep terminals straight after crimping.

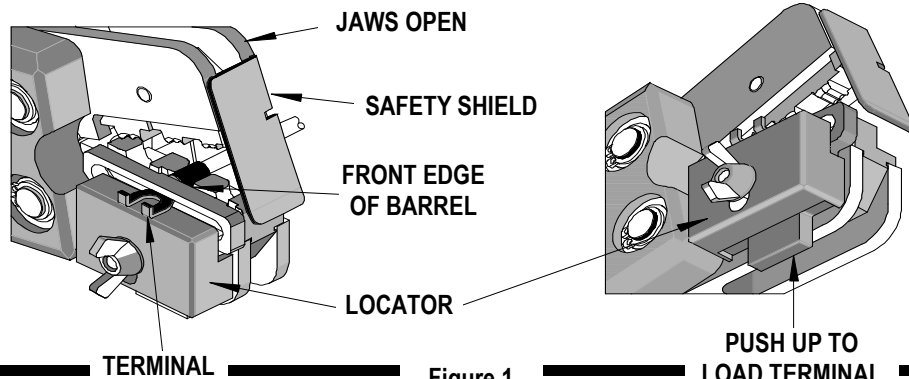
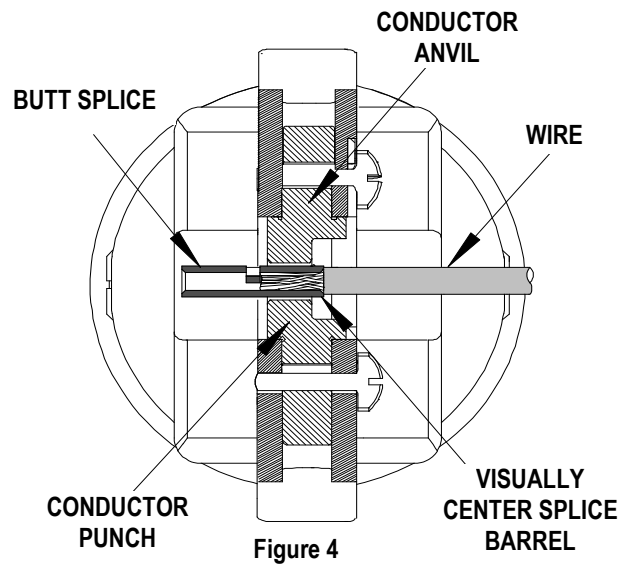
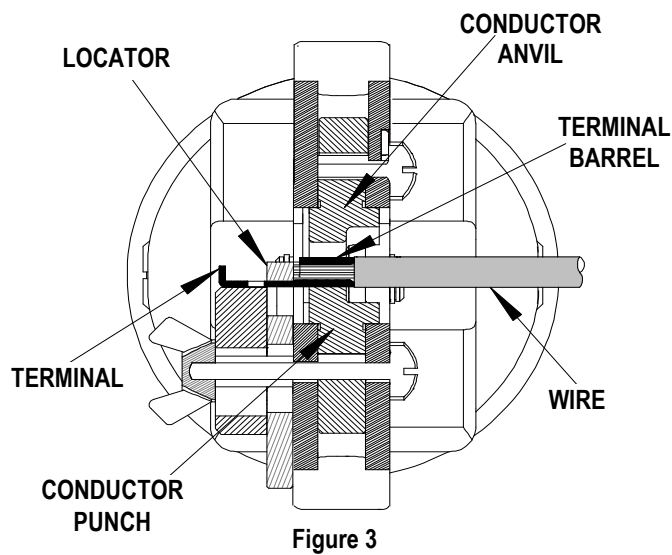

Figure 1 **UNCONTROLLED COPY**

- When crimping butt splices, the locator must be removed. Insert the wire into the butt splice. Position the splice and the wire in proper coded nest with conductor crimp on the conductor barrel of the splice. The splice should be approximately centered inside the tooling nests. See Figure 4. Cycle the tool.



Note: Whenever crimping without the locator, make sure the seam of the terminal is oriented up or down in the tool if using unbrazed product, as this will provide higher pull force values.

6. When crimping parallel splices, the locator must be removed. Insert the 1st wire into one end of splice then insert the 2nd wire into the opposite end of the parallel splice. This procedure will crimp both wires at the same time. Make sure the wires are fully seated into the parallel splice. Position the splice and the wires in proper coded nest with conductor crimp on the conductor barrel of the splice. The splice should be approximately centered inside the tooling nests (See Figure 5). Cycle the tool.

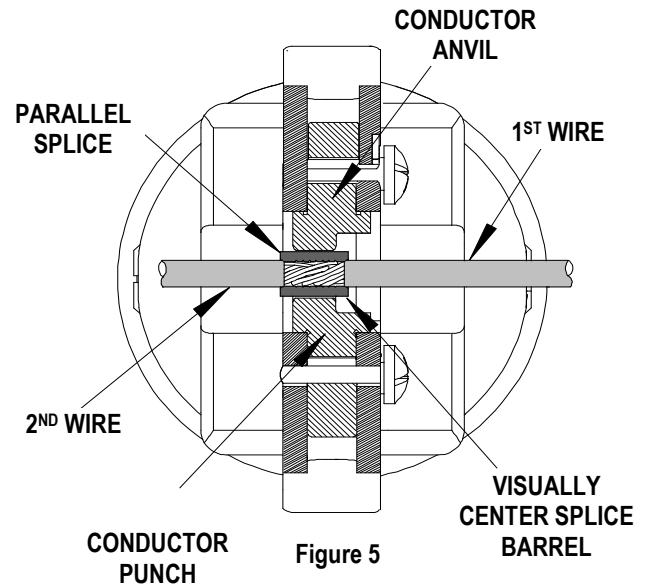

Maintenance

It is recommended that each operator of the tool be made aware of, and responsible for, the following maintenance steps:

1. Remove dust, moisture and other contaminants with a clean brush, or soft, lint-free cloth.
2. Do not use any abrasive materials that could damage the tool.
3. Make certain all pins, pivot points and bearing surfaces are protected with a thin coat of high quality machine oil. Do not oil excessively. The 64007-0100 (AT-1992) was engineered for durability, but like any fine piece of equipment it needs cleaning and lubrication for a maximum service life of trouble-free crimping. A light oil, such as 30 weight automotive oil used at the oil points shown in Figure 6, every 5,000 crimps or monthly will significantly enhance the tool life and ensure a stable calibration.
4. When tool is not in use store the tool in a clean, dry area.

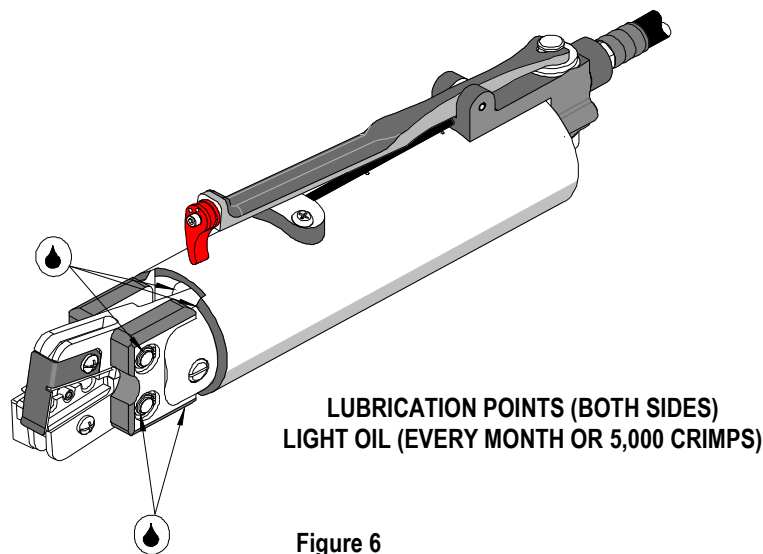

Tool Calibration

A Certificate of Calibration (See last page) was supplied with the tool. To recalibrate this tool, measurements should be taken from each conductor nest and compared to this chart. The tool should be lubricated prior to recalibration to ensure consistent measurements.

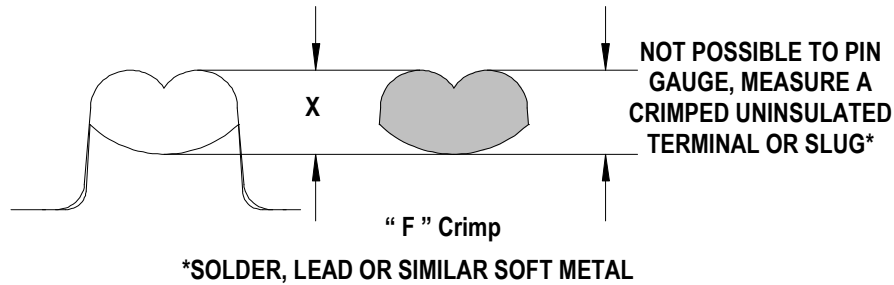

Nest Color Code	Wire Range		"X" Dimension Conductor Crimp		
	AWG	mm ²	Mean	Go	No Go
Red	22 - 18	0.35 - 0.80	.073	.068	.078
Blue	16 - 14	1.30 - 2.00	.095	.089	.101
Yellow	12 - 10	3.30 - 5.00	.127	.121	.133

Warranty

This tool is for electrical terminal crimping purposes only. This tool is made of the best quality materials. All vital components are long-life tested. All tools are warranted to be free of manufacturing defects for a period of 30 days. Should such a defect occur, we would repair or exchange the tool free of charge. This repair or exchange will not be applicable to altered, misused or damaged tools.

PARTS LIST

Item	Order No	Description	Quantity
	64007-0100	Crimp Tool Head	(Fig. 7)
1	64005-0000	Basic Air Tool Head	1
2	64007-0375	Locator Assembly	1
3	64003-0170	Tooling Kit	1
Tooling Kit Only			
4	64001-0102	Conductor Anvil	1
5	64001-0101	Conductor Punch	1

** The following purchased parts are available from an Industrial supply company such as MSC (1-800-645-7270).

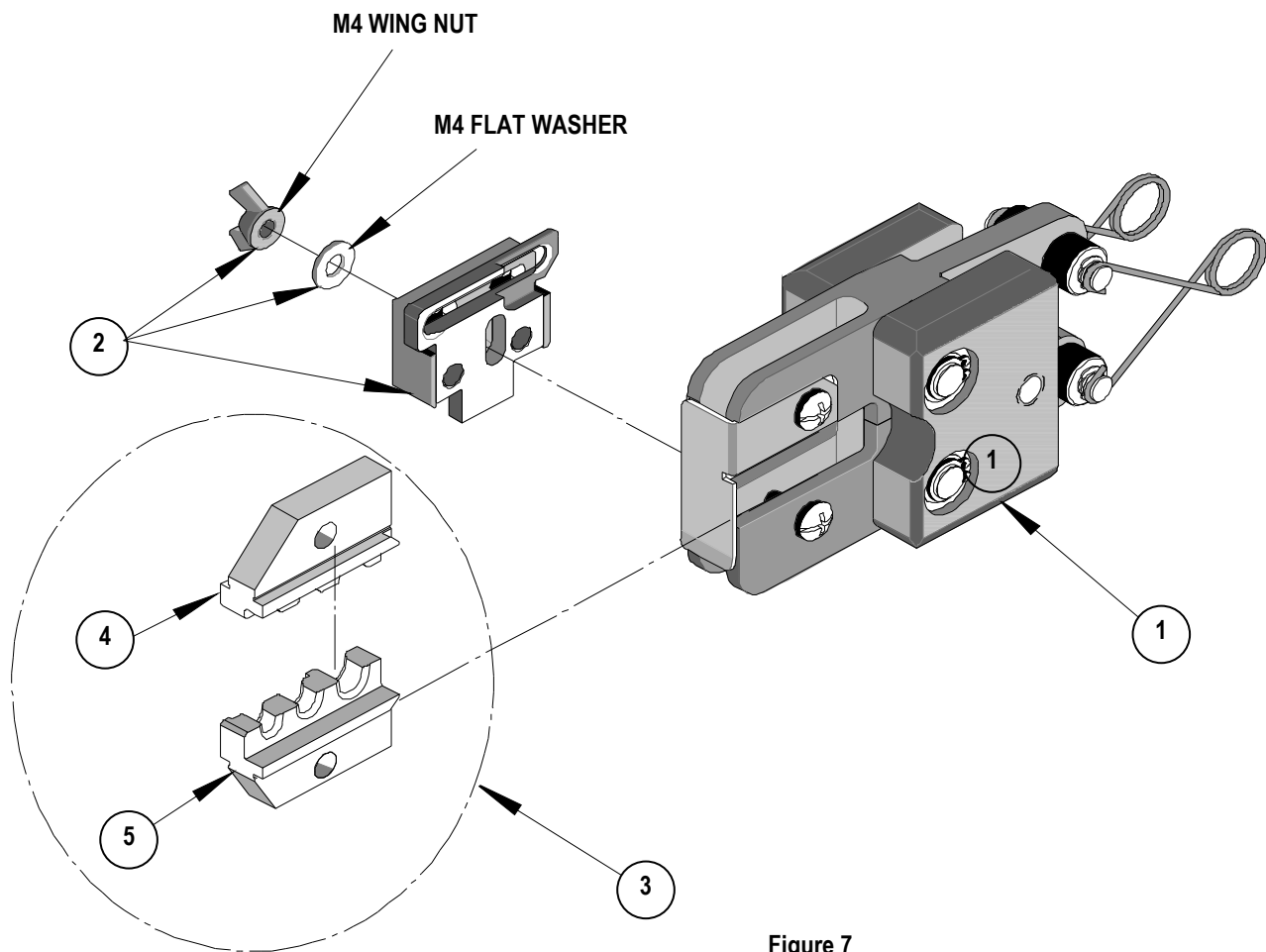

Figure 7

Parts List (Continued)

Item	Order No.	Description	Quantity
	64005-0000	Basic Air Tool Head	(Fig. 8)
1	64005-0103	Nose Guard	1
2	64000-0077	Repair Kit (Springs, Rods, Pivots, Rings, and Washers)	1
3	N/A	M4 by 12LG. Freedrive Pan Head Screw	1**
4	N/A	M4 by 30LG. Freedrive Pan Head Screw	1**
5	N/A	3/16" by 3/8" Long Dowel Pin	1**

** The following purchased parts are available from an Industrial supply company such as MSC (1-800-645-7270).

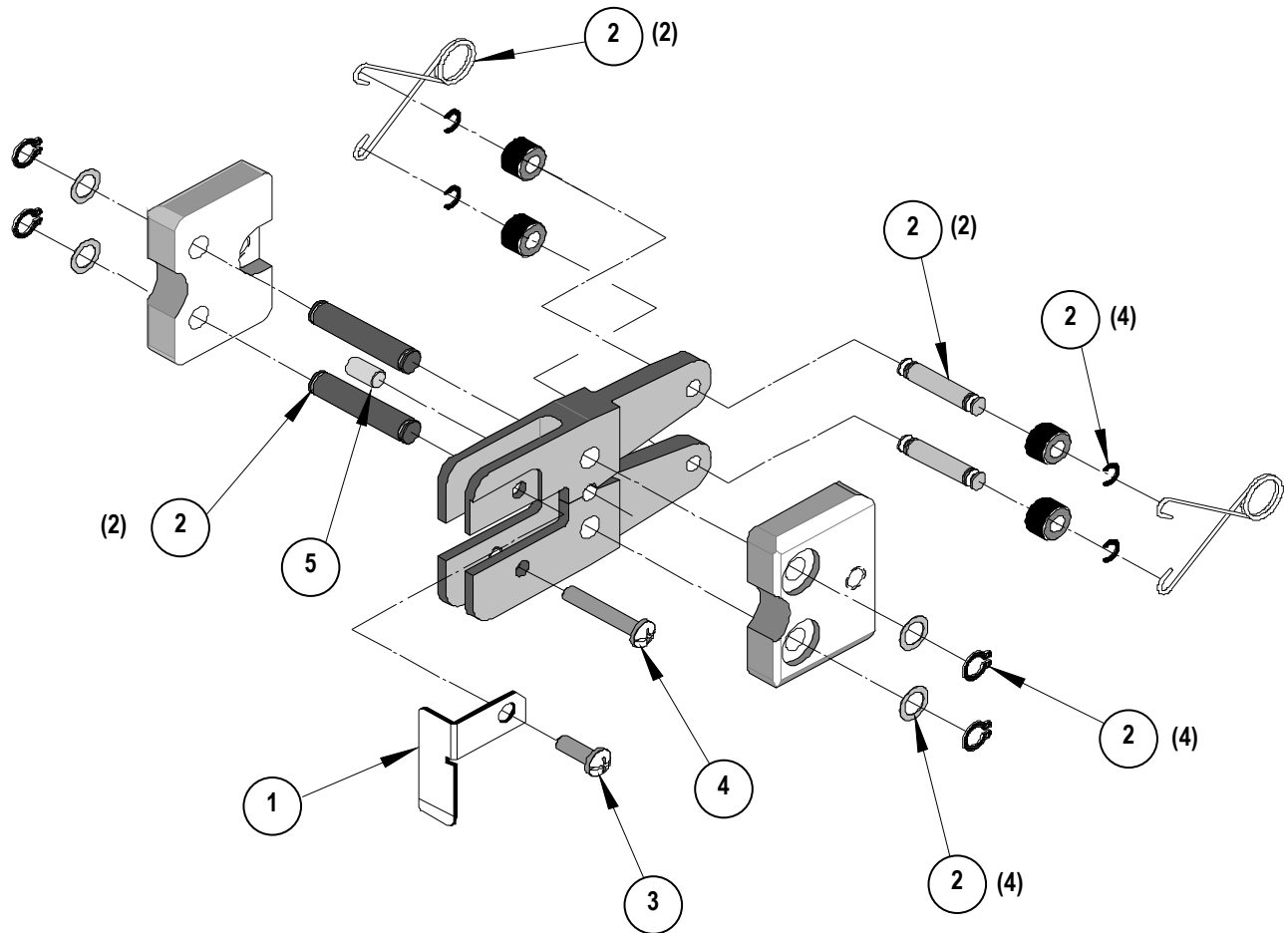
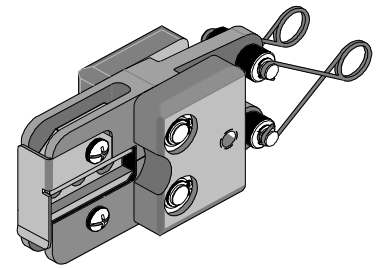

Figure 8



Certificate of Calibration

Tool Order Number -----

Tool Eng. Number -----

Tool Revision -----

Serial Number -----

Date of Manufacture -----

Pin Gauge of Conductor Nest/Nests or Slug height if the nest is the "F" Crimp style.

Range Conductor Nest # 1 = ----- Actual = -----

Range Conductor Nest # 2 = ----- Actual = -----

Range Conductor Nest # 3 = ----- Actual = -----

Technician -----

Date of Calibration -----

Calibration should be done every 5,000 cycles or 3 months.
Tools should be lubricated during this operation.

**Americas
Headquarters**
Lisle, Illinois 60532
U.S.A.
1-800-78MOLEX
amerinfo@molex.com

**Far East North
Headquarters**
Yamato, Kanagawa, Japan
81-462-65-2324
feninfo@molex.com

**Far East South
Headquarters**
Jurong, Singapore
65-6-268-6868
fesinfo@molex.com

**European
Headquarters**
Munich, Germany
49-89-413092-0
eurinfo@molex.com

**Corporate
Headquarters**
2222 Wellington Ct.
Lisle, IL 60532 U.S.A.
630-969-4550
Fax: 630-969-1352

Visit our Web site at <http://www.molex.com>